



## EARTH LEAKAGE RELAY

Earth Leakage relay is used for the continuous surveillance of the earth leakage current which causes generation of heat & progressive failure of insulation, when the current value moves outside from the desired zone the relay energises to give an alarm or trip a circuit.

### PRINCIPLE OF OPERATION

The unit employs a CBCT ( Core Balance Current Transformer) to sense the Leakage Current. In a healthy system the Vector sum of the currents flowing in the 3 Phases is Zero. But in case of an Earth Fault / Leakage the vector sum is not Zero & a resultant current begins to flow. This is sensed and converted into an analog Voltage signal which is compared with a preset reference value. Incase of 3 Phase 4 Wire system Neutral also has to be passed through the CBCT.

### CORE BALANCE CURRENT TRANSFORMER ( CBCT )



### SIZES AVAILABLE

- ✓ CBCT 35mm ID { ABS Plastic Moulded} Sensing  $I_{\Delta n}(A)$ : 30mA to 30 Amps.
- ✓ CBCT 70mm ID { ABS Plastic Moulded} Sensing  $I_{\Delta n}(A)$ : 30mA to 30 Amps.
- ✓ CBCT 120mm ID { ABS Plastic Moulded} Sensing  $I_{\Delta n}(A)$ : 30mA to 30 Amps.
- ✓ CBCT 210mm ID { Tape Wound } Sensing  $I_{\Delta n}(A)$ : 30mA to 30 Amps.
- ✓ CBCT 310mm ID { Tape wound } Sensing  $I_{\Delta n}(A)$ : 300mA to 30 Amps.

Note : Any other ID / rectangular CBCT available on request

### Electrical Wiring /Connection Diagram

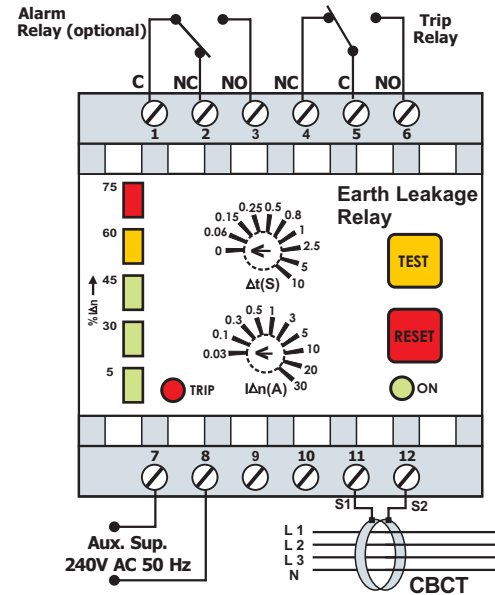

### Safety Precautions :

All safety related codifications, symbols and instructions that appear in this operating manual or on the equipment must be strictly followed to ensure the safety of the operating personnel as well as the instrument.

If the equipment is not used in a manner specified by the manufacturer it might impair the protection provided by the equipment.

If there is physical damage to the unit then do not use it.

Read complete instruction prior to installation and operation of the unit.

### Wiring Guidelines :

- 1) To Prevent the risk of electric shock power supply to the equipment must be kept OFF while doing the wiring arrangement.
- 2) Wiring shall be done strictly according to the terminal layout with shortest connection. Confirm that all connection are correct.

### Caution :

- 1) To ensure the safe operation of unit , check the wiring and connections.

### FEATURES

- State of Art Microcontroller Based Design
- Bar Graph Indication of Leakage Current in %
- User Selectable wide sensing range  
{0.03, 0.10, 0.30, 0.50, 1.0 ,3.0, 5.0, 10.0, 20.0 & 30.0 Amps.}
- User Selectable wide Time Delay range  
{0(40msec.), 0.06,0.15,0.25,0.5, 0.8,1, 2.5, 5, 10 Sec.}
- Alarm Relay Output { at 50% of Set Range}
- Compact Size Din rail mountable.

### APPLICATION

- GeneratorControl Panel
- Distribution Control Panel
- Protection System

### USER SETTABLE PARAMETERS

- ✓ Range Set {  $I_{\Delta n}(A)$  }
- ✓ Delay Set {  $\Delta t(S)$  }

### TECHNICAL SPECIFICATIONS :

|                            |   |
|----------------------------|---|
| Voltage - Rating           | : 240 VAC at 50/60 Hz   |
| Burden                     | : 3VA Max   |
| Current                    | : CBCT Secondary  |
| Overload                   | : x2 continuously, x10 for 3 secs as per BS6253                                   |
| Burden                     | : 3VA Max   |
| Voltage Tolerance          | : - 25% to +10%   |
| Operating temp.            | : -10°C to +70°C  |
| Operating time(Delay)      | : 0{40msec.}, 0.06,0.15,0.25,0.5, 0.8,1,2.5,5,10 Sec.(User adjustable)            |
| Setting of trip point      | : 0.030, 0.10, 0.30, 0.50, 1.0 ,3.0 ,5.0, 10.0, 20.0 & 30.0 A ( User Selectable)  |
| CBCT Sizes (I.D)           | : 35mm,70mm, 120mm & 210 mm   |
| Repeatability of set point | : Better than 0.5%  |
| Alarm Relay Output         | : 50% of Range { $I_{\Delta n}(A)$ } optional Single NO / NC (Contact Rating :5A) |
| Trip Relay Output          | : 80% -90% of Range { $I_{\Delta n}(A)$ } Single NO / NC (Contact Rating :5A)     |
| Status                     | : Normally De-energised   |
| Reset                      | : Manual  |
| Burn in                    | : 48 Hours  |
| Dimensions                 | : 45 x 90 x 75 mm (W x H x D)<br>: Din Rail (35 mm)                               |